



## Split-Case Fire Pump Systems



### CNP NM FIRE FIGHTING SYSTEM CO., LTD

No.45 Xi Chong Road, Quan Tang Street, Changsha ETDZ, Hunan, P.R.China.  
Phone: +86-731-84091707  
Fax: +86-731-84091727  
E-mail: nm-overseas@nanfang-pump.com  
www.nmfirepump.com

**NMFIRE - Mexico**  
Add : Carr. Miguel Alemán km 16.5 #512-F Col. El Milagro  
Apodaca N.L. Mexico C.P. 66634  
Tel México: +52 (81) 8386-6917 / +52 (81) 8331-5193  
Tel Centro y Sudamérica: +52 (81) 8761-7194  
E-Mail: infomexico@gts.com.mx / infocentroysudamerica@gts.com.mx

**NMFIRE - Singapore**  
No. 2 Pioneer Sector 1  
Singapore 628414  
Tel: (65) 6861 1540  
Fax: (65) 68611511  
E-Mail: byeo@chemline.com.sg

All rights reserved.



### CNP NM FIRE FIGHTING SYSTEM CO.,LTD



# Pumping Water Pumping Honor



CNP is a leading global supplier of reliable products and innovative pumping solution for end users, and is active over 60 locations worldwide. We offer dense hydraulic coverage to meet your process needs. Better hydraulic fits can mean improved efficiency and longtime reliability and parts life.

No matter what type of fluid you need to move, chances are that CNP pumps have a pump for your job. All of our pumps have three superior design characteristics: Design, Performance and Durability. Our engineering department, which includes an in-house pattern shop, design each pump to be easy to install and easy to maintain. Our performances are engineered to meet or beat the competition in each category.

For more than 30 years, we have provided very cost effective solutions by building our pumps to last. Durability by design is always the most cost effective solution.

From engineering and design to final assembly, each step of the manufacturing process is controlled by experienced people and state of the art equipment. Quality inspections are performed at every step of the manufacturing process. Pump testing is done in our test facility consisting of a 8000 m<sup>3</sup> test pit and capable of testing up to 5000Kw. All of these factors ensure you receive consistent quality every time.

We are experts in packing engineered pumps that meet your demanding applications.





Precision balancing of all factors in the design of CNP NMFIRE horizontal split case fire pumps provides mechanical dependability, efficient operation and minimal maintenance. Simplicity of design ensures long efficient unit life, reduced maintenance costs and minimum power consumption.

## Application

Split case pumps are specifically designed and tested for fire service application around the world including:

- Office buildings
- Hospitals
- Airports
- Manufacturing facilities
- Warehouses
- Power stations
- Oil and gas industry
- Schools/colleges
- Hotels



## Materials of Construction

To meet the rugged demands of fire protection in industrial and offshore environments, NMFIRE split case pumps are available in:

- Ductile Cast Iron Casing With 304SS Impeller
- 304 or 316 Stainless Steel Wet Parts
- Duplex 2205 Stainless Steel Wet Parts



## Performance Range

NMFIRE split case fire pumps are available for ranging from 500 USgpm to 4000 USgpm and are suitable for electric or diesel drivers. The table below demonstrates how the ranges of split case pumps are designed to meet most normal requirements.

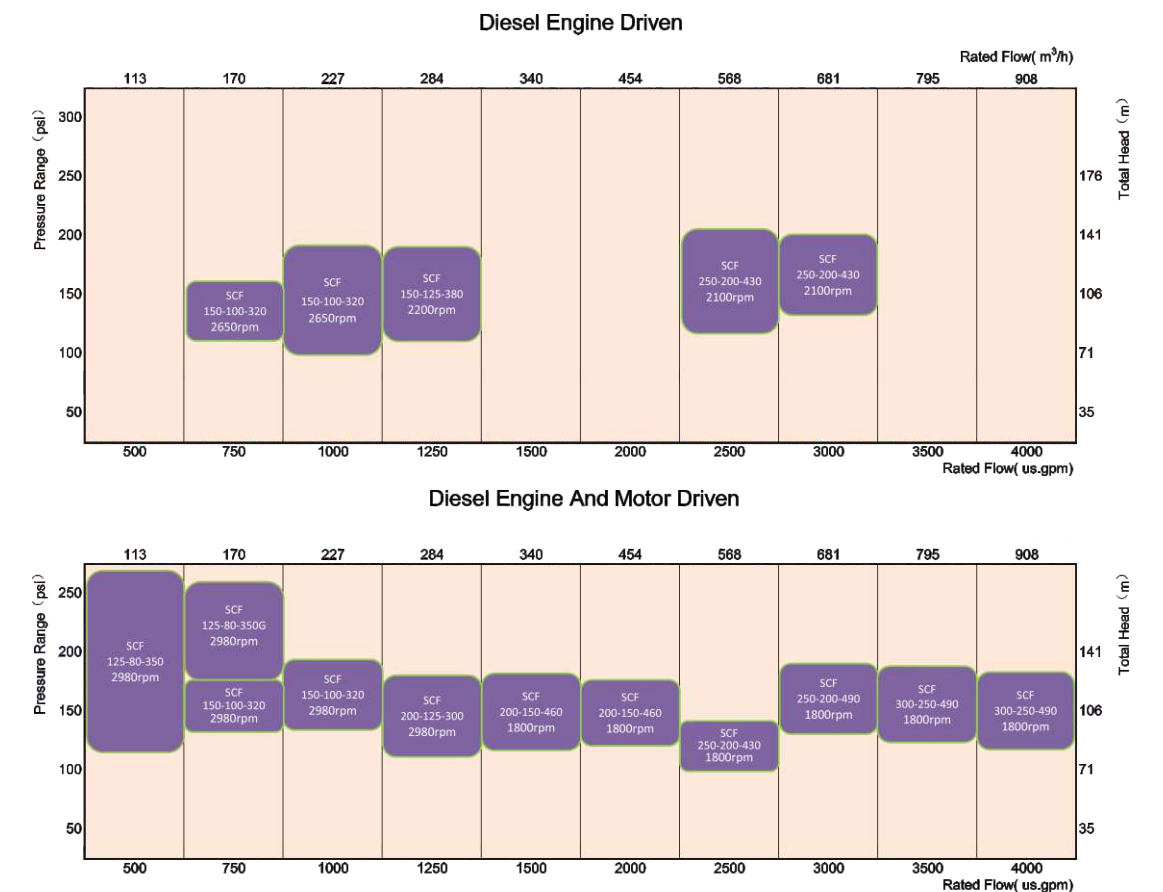



## Fully-assembled package solution

With years of experience in fire protection industry, NMFIRE can supply fire pump systems with all necessary accessories ready for site installation.

Advantages:

- Simplifies piping design
- Single source unit responsibility
- A complete package that will meet NFPA20 requirements
- Packaged systems are performance and hydrostatically factory tested at an ISO9001 certified manufacturing facility prior to shipment.
- No material lost due to on-site material handling
- Improves the speed of construction and reduces on-site installation time
- Only external suction, discharge and power connection are required on-site
- State of the art engineering design

The full range of NM FIRE solutions available includes Horizontal Split Case, End Suction, Vertical In-Line and Vertical Turbine Pumps. Single Electric, Single Diesel, 1 Electric and 1 Diesel, 2 Electric, 2 Diesel configurations are available.

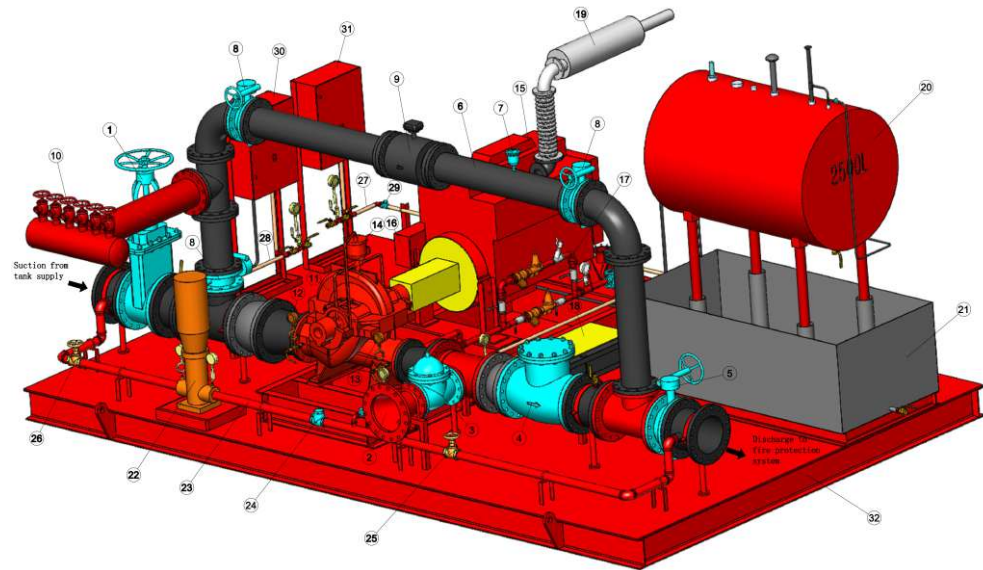

1	OS&Y Gate Valve (Suction Control Valve)	16	Instrument panel
2	Relief Cone	17	Cooling
3	Relief Valve	18	Batteries
4	Check Valve (Pump Discharge)	19	Diesel Drive Exhaust
5	Indicating Gate Valve or Butterfly Valve (Discharge Control Valve)	20	Diesel Fuel Tank
6	The test pipe	21	Oil collector
7	Automatic Air Release	22	Jockey Pump
8	Indicating Gate Valve or Butterfly Valve (Test Header)	23	Jockey Pump pipe
9	Flow Meter	24	Check Valve (Jockey Pump Discharge)
10	Test Header	25	Isolation Valve (Jockey Pump Discharge)
11	Pump	26	Isolation Valve (Jockey Pump Suction)
12	Suction Pressure Gauge	27	Pressure Sensing Line (Jockey Pump)
13	Discharge Pressure Gauge	28	Pressure Sensing Line (Fire Pump)
14	Automatic Air Release	29	Check Valve (Jockey Pump Pressure Sensing Line)
15	Diesel Engine	30	Fire Pump Controller
		31	Pressure Maintenance Pump Controller (Jockey Pump)
		32	Common base

# PUMPING WATER PUMPING HONOR

The protection of life and property is not a matter for compromise. CNP NM Fire offers package systems that meet every life protection need.

